



HRV 010

Protection in even the most severe weather and soil conditions. Critical design elements include virgin material, high grade PE structural foam molding process, "T" top twist lock bolt-ready lids for maximum tamper proof protection. Discoloration UV preventative additives keep HRV boxes looking great for years of extended use even in the harshest of environments. Box strength meets or exceeds industry standards (see load test below).

FEATURES AND BENEFITS

- **HDPE material**—Is slow molded to maintain maximum wall diameter strengthening the entire box and lid
- **"T" top lid**—Increases lid load capability protecting the enclosed valves from damage
- **UV Inhibitor additives**—With anti-oxidants protect the boxes from fading due to direct sun light
- **Resistant to moisture**—Keeps critical irrigation system components from the elements
- **Lock bolt ready**—Stainless steel tamper resistant bolt installed in the molding process on all models
- **Innovative twist lock**—Keeps the lid oriented and latched but readily accessible
- **Structural foam molded**—Provides increased strength through accurate material distribution during the molding process



MODELS

HRV-010-BG-RD	HRV 010 10" Circular Valve Box; Black/Green
HRV-010-GG-RD	HRV 010 10" Circular Valve Box; Green
HRV-010-TT-RD	HRV 010 10" Circular Valve Box; Tan

HOW TO SPECIFY

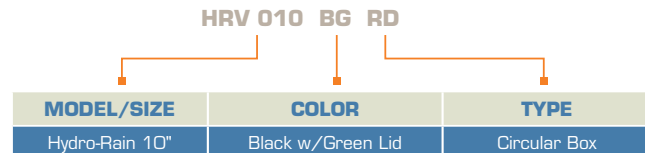



HRV 010

MATERIAL SPECIFICATIONS

* PROPERTIES OF BASE MATERIAL	ASTM TEST METHOD	HDPE
Tensile Strength	D-638	2,700-4,400 psi (Typical Range)
Flexural Modulus	D-790	Min 140,000 not to exceed 240,000 psi
Notched Izod Impact Strength	D-256	0.5-3.0 (Typical Range)
Density	D-792	Min 0.95 not to exceed 0.965
Deflection Temp @ 66psi	D-648	150° to 200° F
Electrical Dielectric Strength	D-149	400-600 V/mil (Typical Range)
MOLDED PRODUCT	ASTM TEST METHOD	HDPE
Chemical Resistance	D-543	Very Resistant
Water Absorption	D-570	≤ 1% weight change
Static Vertical Load Rating	C-857	A-0.3, 300 lb. ft./ft ²

*Material specifications subject to change based on availability

CIRCULAR BOX

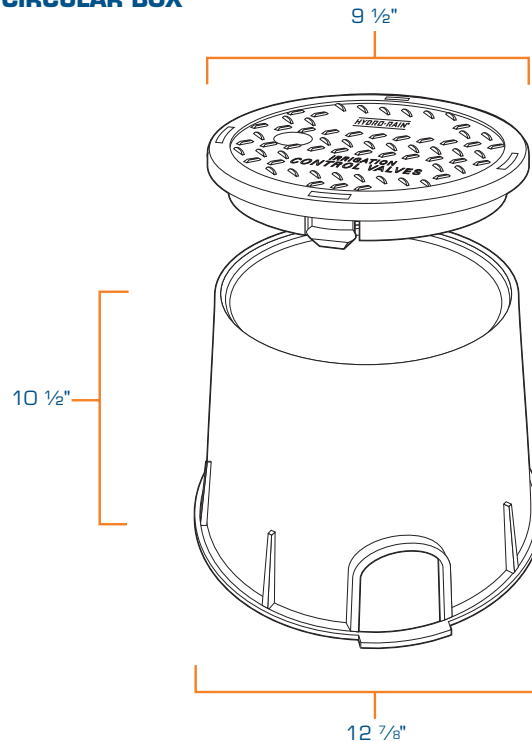

BOX STRENGTH - CRUSH TEST

VALVE BOX BODY LOAD	MAXIMUM LOAD LBS.	DEFLECTION INCHES
10" Round	11,675	0.490

VALVE BOX LID LOAD	MAXIMUM LOAD LBS.	DEFLECTION INCHES
10" Round	4,688	0.650

03304-36 Rev A